

Digital Audio Data Transmission Transformers

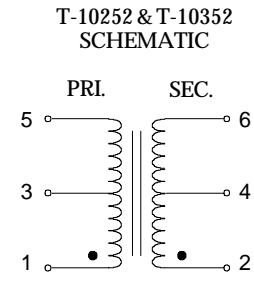
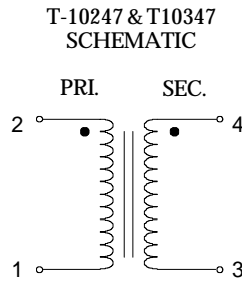

Electrical Specifications at 25°C

| Parameter | "T6" Package P/N SMD Package P/N | T-10247 ⁽²⁾ T-10347 | T-10252 ⁽³⁾ T-10352 | Units |
|--------------------------------------|-------------------------------------|-----------------------------------|-----------------------------------|------------------|
| Turns Ratio | | 1:1 ± 5% | 1CT:1CT ± 5% | |
| Inductance | 100 kHz & 0.1V _{RMS} | 2.5 ± 20% | 5.0 ± 30% | mH |
| Leakage Inductance | 100 kHz & 0.1V _{RMS} | 0.5 max. | 1.2 max. | μH |
| Rise Time | | 25 max. | 25 max. | nS |
| DC Resistance | | 0.7 max. | 1.0 max. | Ω |
| Isolation (HI-POT) | | 2000 min. | 2000 min. | V _{RMS} |
| ET Product | | 20 | 25 | VμS |
| Common Mode Rejection ⁽¹⁾ | | 70 min. | 70 typ. | dB |
| Return Loss | 100Hz to 100kHz | 15 min. | 15 typ. | dB |
| Operating Temperature Range | | -40° to +85° | 0° to +70° | °C |

1. @ 1MHz in 100Ω System

- T-10247:** For Use with Crystal Semiconductor's integrated circuits CS8401, CS8402.
For Surface Mount Version Order Part Number T-10347
- T-10252:** For Use with Echelon Neuron integrated circuits 3120 and 3150 Chips produced by Motorola and Toshiba.
For Surface Mount Version Order Part Number T-10352

These Transformers provide excellent DC isolation and common mode noise rejection

Designed to improve and maintain the balance of the transmitter and receiver circuitry.

Designed for low cost.

High voltage isolation

Available in Surface Mount Versions

Custom Designs and Variations of these transformers available

Flammability: Materials used in the production of these units meet requirements of UL94-VO & IEC 695-2-2 needle flame test.

Parts shipped in anti-static tubes.
50 pieces per tube

Physical Dimensions
in inches (mm)

(Unused Pins Omitted)

"T6" Package
T-10247 & T-10252

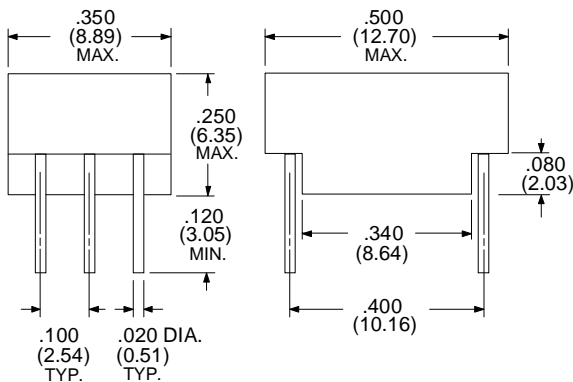

Surface Mount Package
T-10347 & T-10352
Tape & Reel Available

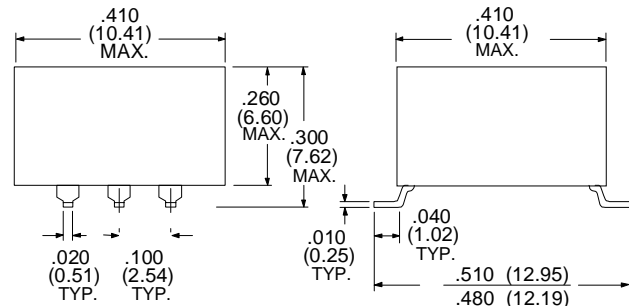

For Complete Details including
PDF Catalogs & Data Sheets on this
and other product families visit

www.rhombus-ind.com