

T-984G

HDSL

TRANSFORMER

Designed for HDSL applications

Compatible with Brooktree BT8960 at 160 kbps

Custom versions of this transformer are available.

PARAMETER		UNITS
Turns Ratio	2 : 1 \pm 1%	
Line Impedance	135	Ω
Inductance (Line Side)	8.0 \pm 6%	mH
Longitudinal Balance 40 kHz to 200 kHz	53 min.	dB
Primary DC Resistance	4.0 Max.	Ω
Secondary DC Resistance	2.3 Max.	Ω
Frequency Response 40kHz - 300kHz	\pm 0.2	dB
Insertion Loss @ 200kHz	0.4	dB
Isolation (HI-POT)	1500	V _{RMS}
Primary DC	60	mA
Return Loss @ 40kHz	16 min.	dB
THD (40 KHz, 14 dBm)	-70 Min.	dB

SCHEMATIC DIAGRAM:

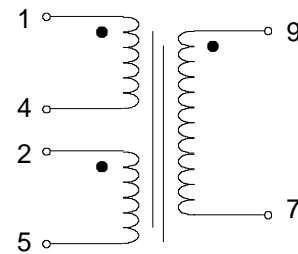

Line Side Pins 1-4 + 2-5
Device Side Pins 9-7

Physical Dimensions in inches (mm)

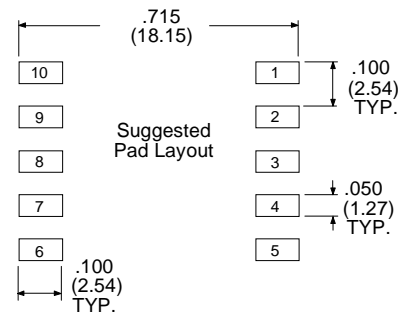
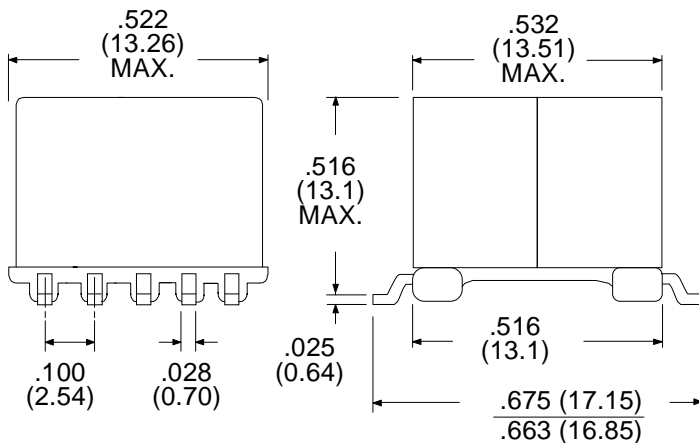

1/22/96