

ISDN S-Interface Dual Transformer

Reinforced Insulation Per EN 41003/EN 60950

Turns Ratio Pins 1-4:16-13 & 5-8:12-9	1:1 & 1:1
---------------------------------------	-----------

SCHEMATIC DIAGRAM

PARAMETER	MIN.	MAX.	UNITS
Open Circuit Inductance 1-4 ⁽¹⁾ 5-8 ⁽²⁾	22		mHy
Leakage Inductance 1-4 ⁽¹⁾ Short 16-13 ⁽³⁾ 5-8 ⁽²⁾ Short 12-9 ⁽⁴⁾		5 5	μ Hy μ Hy
Interwinding Capacitance ($C_{W/W}$) 1-4 ⁽¹⁾ & 16-13 ⁽³⁾ 5-8 ⁽²⁾ & 12-9 ⁽⁴⁾		100 100	pF pF
Distributed Parallel Capacitance 1-4 ⁽¹⁾ 5-8 ⁽²⁾		40 40	pF pF
Primary DC Resistance: 1-4 ⁽¹⁾ ; 5-8 ⁽²⁾	2.04	2.76	ohms
Secondary DC Resistance: 16-13 ⁽³⁾ ; 12-9 ⁽⁴⁾	2.04	2.76	ohms
Isolation (HI-POT)	4000		V_{RMS}

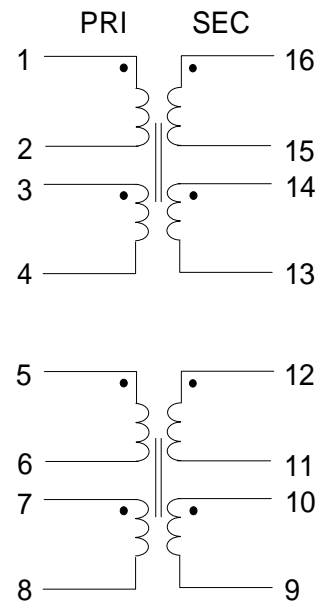

MEETS THE PULSE WAVEFORM TEMPLATE OF CCITT I.430.

- ✦ Primary is Line Side
- ✦ Unbalanced current at TE: $\Delta I_{dc} = 1 \text{ mA}_{max}$.
- ✦ Longitudinal Conversion Loss - 10KHz to 300 KHz: 60dB min.

Flammability: Materials used in the production of these units are UL94-VO and meet requirements of IEC 695-2-2 needle flame test.

Parts shipped in anti-static tubes. 18 pieces per tube

Package Dimensions in Inches (mm)

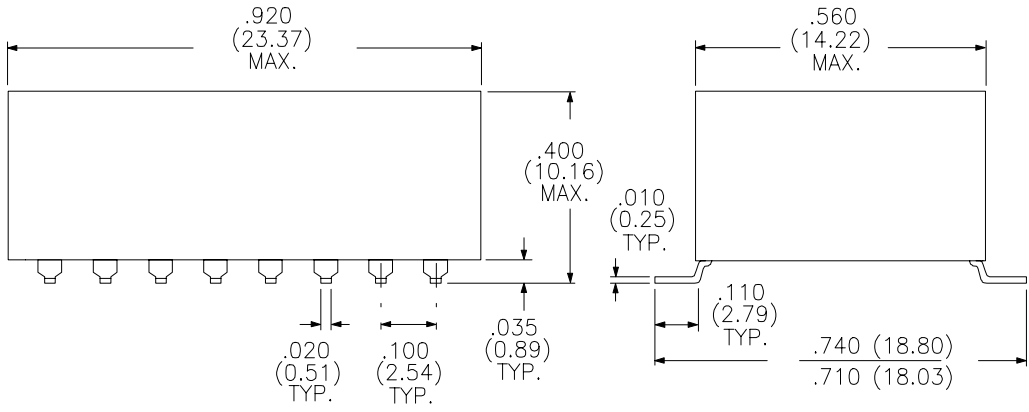

Oscillation Voltage = 700mV
Oscillation Frequency = 10.0 KHz

1. Connect Pins 2 & 3
2. Connect Pins 6 & 7
3. Connect Pins 14 & 15
4. Connect Pins 10 & 11

RHOMBUS P/N: T-13551	
CUST P/N:	NAME:
DATE: 3/24/94	SHEET: 1 OF 1