

T1/CEPT PULSE TRANSFORMER

UL 1459 Recognized 

Turns Ratio ($\pm 5\%$) 1:1:1.58
 Shorting pins 2+3 create a 1.26CT : 1 Turns Ratio
 Primary Pins 1-4, Secondary Pins 5-6

Flammability: Materials used in the production of these units meet requirements of UL94-VO and IEC 695-2-2 needle flame test.

Temperature Characteristics:
 -40° C 210 μ H min. (30% drop in inductance)
 +85° C 375 μ H min. (25% growth in inductance)
Typical part:
 0.35 mH @ +25° C
 0.44 mH @ +85° C
 0.25 mH @ -40° C

PARAMETER	MIN.	MAX.	UNITS
Open Circuit Inductance Oscillation Voltage = 20mV Oscillation Frequency = 100.0 KHz	0.3		mHy
Leakage Inductance Oscillation Level = 20mV Oscillation Frequency = 100.0 KHz		0.60	μ Hy
Interwinding Capacitance (C_{WW}) Oscillation Frequency = 100.0 KHz		30	pF
Primary DC Resistance		0.8	ohms
Secondary DC Resistance		0.6	ohms
Isolation (HI-POT)	1.5 Kv		VRMS

Parts shipped in anti-static tubes. 50 pieces per tube

1. All parameters tested

Shorting pins 2+3 create a 1.26CT : 1 Turns Ratio
 Primary Pins 1-4, Secondary Pins 5-6

PHYSICAL DIMENSIONS
 All dimensions in inches (mm):

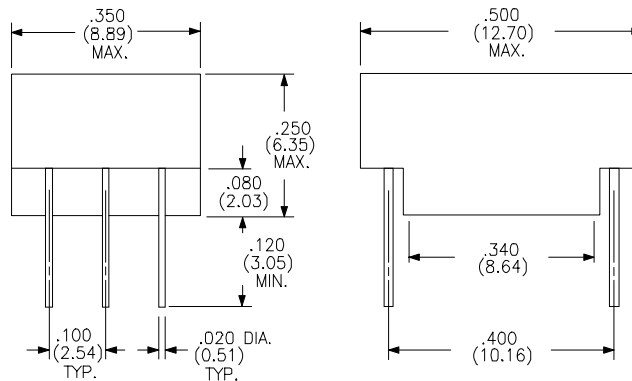

SCHEMATIC DIAGRAM:

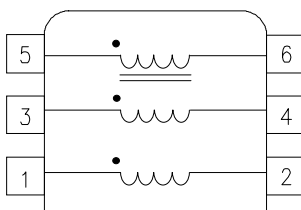

RHOMBUS INDUSTRIES INC.
FSCM NO. 16714

RHOMBUS P/N: T-10207

CUST P/N:

NAME:

DATE: 2/19/96

SHEET: 1 OF 1